

User manual

Urban Arrow Cargo L



Introduction

Welcome to this DOCKR user manual.

This manual will teach you how to get the most out of your new DOCKR cargo bike. These modern electric powered bicycles are ideal for sustainable mobility. They are much cooler than your regular bicycle but do require a little extra training.

We have a lot to share with you, so let's get started. This cargo bike is, of course, quite a bit bigger than the bicycle you have at home. In other words, you're taking up quite a bit of space on the bicycle lane. Be aware of this and anticipate oncoming traffic. DOCKR cargo bikes are ideal for transporting large quantities of goods.



Specifications

Fully loaded, they weigh more than a motorcycle. Always make sure your tires are properly inflated before you set off. Naturally, the cargo bike has a large cargo box. The L has the so-called DOCKR box with a capacity of 400 L. That's more than a hatchback. You open the box with a separate, larger key, turn the knob, and the lid unlocks. Be sure to insert the key properly before turning, otherwise the key may break off. The bicycle has an adjustable saddle for people between 155 centimeters and 195 centimeters.

DOCKR cargo bikes have a display with which you can regulate the bicycle settings. The bicycle's display has buttons that allow you to control all the functions, but how do all those functions work in practice? Let me walk you through your first steps when using the cargo bike.

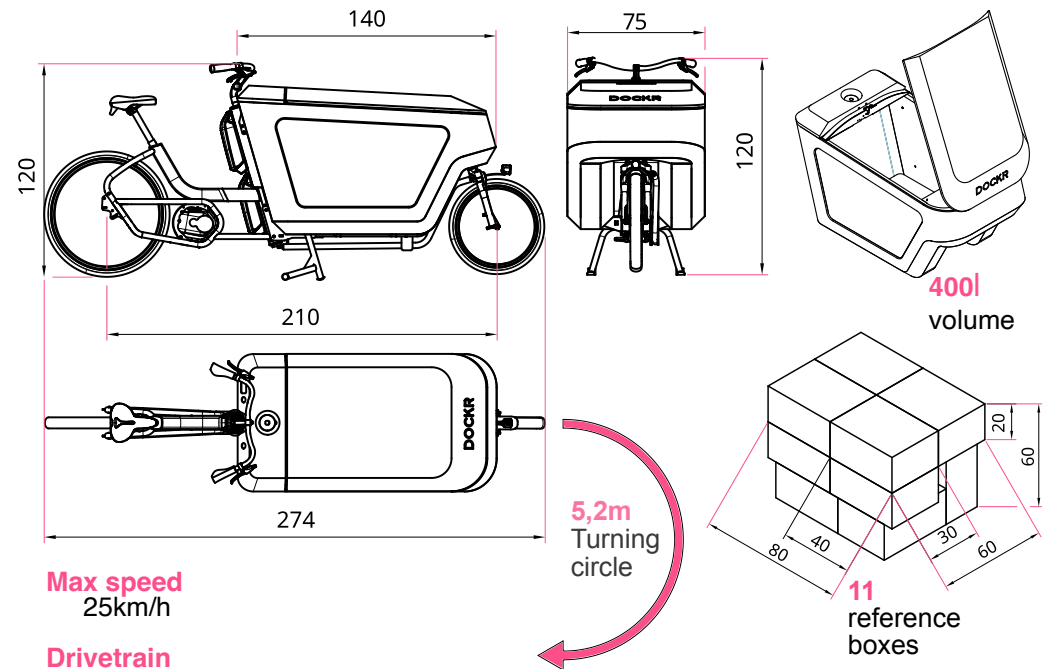

Max speed
25km/h

Drivetrain
Bosch Cargo Line
Enviolo Heavy Duty with AUTOMATIQ® shifting
Gates belt drive

Battery
500Wh
2 battery docks

Range
40km on a single battery
80km on dual batteries

Vehicle weight
65kg

Permissible total weight
250kg

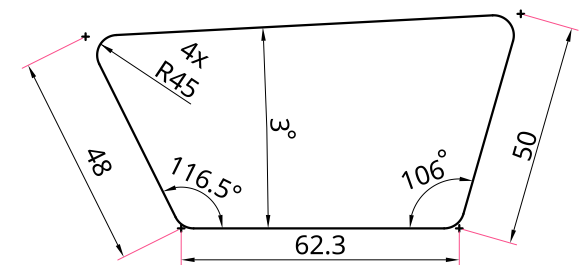

Branding
Left and right 0,36 m² brand panel

Ready for your ride?

First, assess the condition of the cargo bike. Are the tires still adequately inflated? You check this by placing some weight on the bicycle and checking whether the tires flatten. The tires may only flatten slightly, even with a fully loaded cargo box. Can the cargo box be closed properly? If you detect any defects, you can take a photo or report it, then take the battery and connect it to the bicycle frame. You do this by aligning the connections and clicking the battery into the frame.

Always use two hands because you don't want your battery to fall on the ground. A damaged battery can be a fire hazard. Press and hold the power button. Once the screen is on, walk around your bike and check if both lights are working. Do not forget to turn off the lights when you're not using them to extend battery life. Adjust the saddle before you start cycling.



Saddle position

Make sure your saddle is positioned so that both feet barely touch the ground. This is approximately the same height as your hip. This position ensures that you do not have to pull up your legs too much while cycling. This will decrease the chance of injuries and make your journey way more comfortable.

And pro tip: look under the saddle and take note of the set height so you can easily adjust it the next time. The saddle and handlebars are preset to a comfortable position. Will you be taking several trips on the same bicycle, or is the height of the saddle or handlebars really not comfortable for you? Then you can use a wrench to further adjust them to a perfect position.

The bicycle has an adjustable saddle for people between 155 cm and 195 cm.

Adjustable Saddle



Loading your DOCKR

After this, you check your load and the cargo box. Is it secured or is everything inside the cargo box going to fly around when you cycle around a corner? Also, make sure that heavy cargo items are placed closer to the handlebars and lighter items closer to the wheel. This creates better balance while cycling. The cargo box is splash-proof. This means that your cargo will generally stay dry. A little water might seep in, but only during heavy downpours. In that case, simply let the water drain so your goods will be dry when delivered.

Finally, you can inspect the drive belt for dirt. This belt is probably located in the same spot as your own bicycle's chain. Dirt collects here, especially in colder months, and it is best to brush it off before heading off. This prevents the gears from jamming and you from cycling any further. Ready to hit the road?



Your first ride

Be sure to insert the key properly before turning and make sure your bicycle is unlocked. Take it off the stand using both hands. We recommend that you always start your first trip in a low power mode. This way, you can get used to the electric support.

Position the pedal of your bike so that you can easily apply power when setting off. Try to do this as much as possible. When setting off, immediately test whether the brakes are working properly. We recommend that you brake using both brakes wherever possible. If you have to brake hard, keep applying pressure on the pedals.

This may feel counterintuitive, but it will keep your tires from losing grip and help you stop as quickly as possible. Are they working properly? Then you can continue on your way.

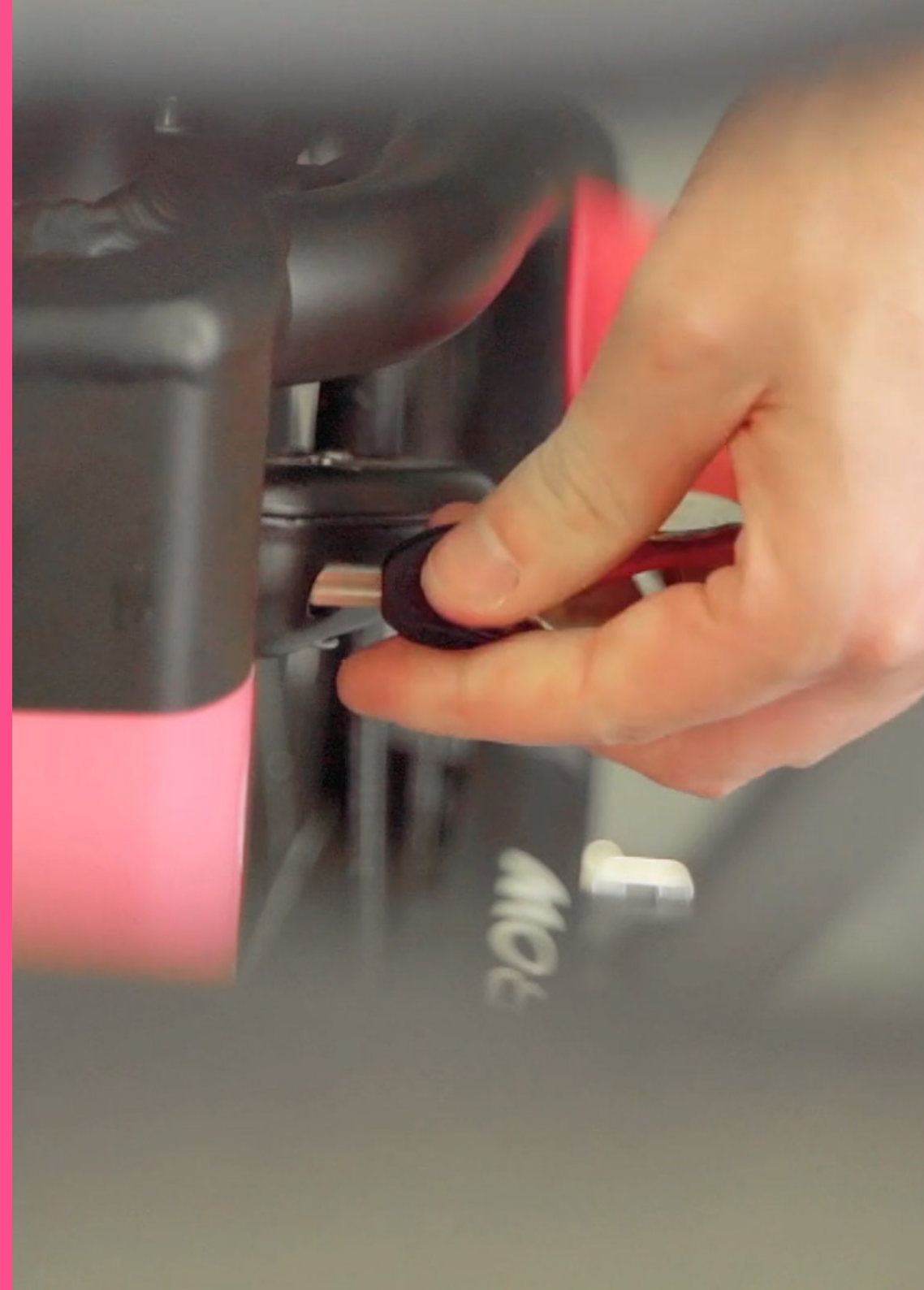

Electrical support

Try out the more powerful modes if you feel comfortable doing so. You will notice an extra thrust and you have to pedal even less. However, this does limit your range, so we recommend always using a lighter mode because the bicycle already provides enough support and it gives you more control over the power delivery. The most powerful mode is only recommended for steep hills where extra support is needed.

When you are mingling with other traffic, you must always bear in mind the dimensions and weight of your bicycle. Performing an unexpected evasive maneuver is a lot more complicated.



Be aware on the road

While on the move, it's best to imagine a similar-sized box in the shape of your bike, floating a few meters in front of you. This allows you to better assess whether certain situations could get tricky. Overtake other cyclists with a wide angle and not too fast to prevent them from reacting startled. You will often cycle among a variety of road users, and not everyone is able to anticipate your possibly higher speed. Reduce your speed when traffic picks up and anticipate unexpected manoeuvres by other road users so you can react accordingly if necessary.

While cycling, assess whether you will fit in narrow streets or alleys along with oncoming traffic. If not, you may want to choose a different route. When approaching busy intersections or roundabouts, reduce your speed. And most importantly, priority is not something you take.



Behavior on the road

So first, check to see if the person on the left has seen you and slows down or stops before you cross the road. Do you intersect with another lane when turning? Then look back over your shoulder to make sure that there's no oncoming traffic. This prevents painful situations and do you have to wait at a red light? Then you should join at the back of the queue. You take up a lot of space with your bicycle and it is your responsibility to save space for other road users. You can pass slower cyclists as soon as you are on your way again.

DOCKR cargo bikes are extremely useful for last mile delivery, but these areas do not always consist of smooth stretches of asphalt. Avoid potholes, slow down at large speed bumps, and only use the sidewalk while walking. The bicycle can take a beating, but taking these obstacles at full speed is not a smart move.



Respect each other

Finally, you should remember that your cargo bike serves as a mobile business card. Careless cycling behavior does not only negatively affect your own image, but also that of your employer. Once you arrive at your destination, you can't just leave your bicycle on the road. You should park it so that you do not block traffic. Is your destination in a pedestrian area such as a shopping street or on the sidewalk? And is your bicycle too heavy to push? Then you can use the walk support. This is done via the display.

The bike will then automatically start moving at walking speed. When you arrive at your destination, keep one hand on the handlebars and one on the saddle and put your foot on the stand. Pull the bicycle back so that the stand pops out. Make sure both contact points of the stand are touching the ground before you pull the bicycle backwards because you don't want your bicycle to fall over while making a delivery.



The end of your ride

Did you enjoy the ride? Now it's time to make sure the next cyclist can also have a good time. So when you return, put your bike back on its stand with both hands and make sure you leave the cargo box clean and dry. Then check for any damage or defects such as a flat tire or a dent in the frame. Lock the bicycle and disconnect the battery from the frame. Take the battery and connect it to the charger. Awesome!

Now the bicycle will be ready to go again in a few hours. Thank you for reading this DOCKR user manual. I hope we managed to provide you with new information on the use and conveniences of your DOCKR cargo bikes. We wish you many safe kilometers.





Do you still have questions?

[Contact us!](#)